



ProFlow™ Series
LoBoy™ Drum Carts

1350 Rockefeller Rd., Wickliffe, OH 44092, PH 440.943.4111, info@KtecInc.com, www.KtecInc.com

LOBOY™ DRUM CARTS

K-Tec low ground clearance carts deliver flexibility and top quality to complement **lean material flow** programs.

- 100% HD Welded Frame, Powder Paint Finish
- Ultra-low 2.3" Deck Height, 1000lb. Capacity
- Auto-release Floor Lock
- Auto-hitch and Self Stowing, HD Towbar
- Low Push/Pull Force 4-Wheel System
- Leak-proof Containment Pan
- Caster Steering, No Kingpins, Sealed Bearings

INDUSTRY LEADING DESIGN

Carts meet standard ergonomic limits for manual push / pull forces with heavy payloads and standup to tough loading conditions. FEA (finite element analysis)

puts stiffness and weight where needed to produce carts as light and rugged as possible. Numerous "attention to detail" features help K-Tec meet rigorous **safety**, reliability and durability standards. K-Tec ProFlow™ Series carts carry a **two (2) year warranty**.¹

COMMITMENT TO SUCCESS

K-Tec identifies and benchmarks relevant applications, addresses ergo/safety issues and provides on-site feasibility reviews where required. Application engineers are available by conference call or direct appointment to help walk through the early planning and front end design phase of lean material flow projects.² K-Tec also designs ergo-support products such as lifts and conveyors to provide an integrated, dependable solution. A "try before you buy" **demo program** for qualified customers delivers a hands on look at a forklift free solution without wasting investment dollars.



1. See web site for warranty detail. 2. May be subject to consulting charges.

Distributed By:

Lean Material Flow Solutions

LoBoy™ Drum Carts

1350 Rockefeller Rd., Wickliffe, OH 44092, PH 440.943.4111, info@KtecInc.com, www.KtecInc.com

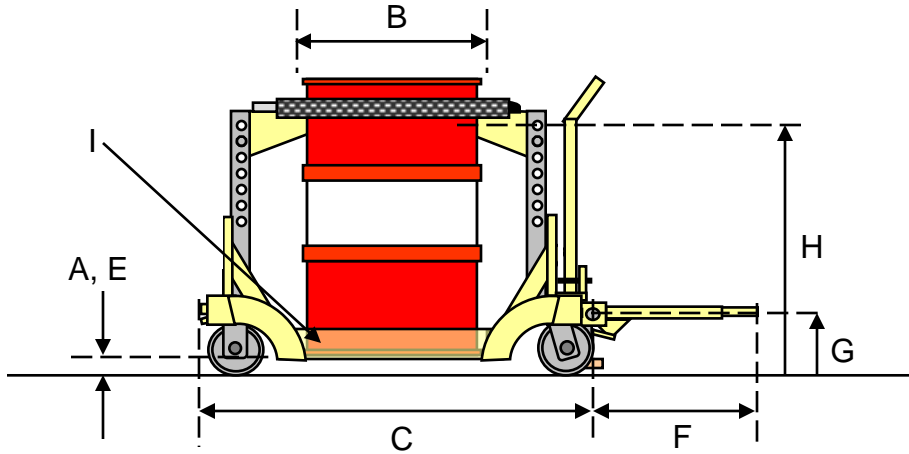

LoBoy Drum Carts

Model: KT1-55LD

Dimensions	
Floor to Drum Deck, A	2.5"
Support Cradle Diameter, B	24.5"
Overall Cart Length, C	52"
Overall Cart Width, D	33"
Floor to Frame Bottom Clearance, E	2.3"
Towbar Length (eyelet diameter 2.5"), F	20"
Towbar Height, G	11.25"
Floor to Support Cradle (adjustable), H	30.2"
Containment Pan Lip, I	3"
Standard Features	
4-Wheel Caster Steer w/Kingpinless Swivels, Hybrid Low Push/Pull Force	✓
6-Wheel Caster Steer w/Kingpinless Swivels, Hybrid Low Push/Pull Force	
Welded Steel, Industrial-Duty Perimeter Frame w/Powder Paint Finish	✓
Adjustable Height, Removable Steel Drum Support Cradle (w/seat belt retainer)	✓
Precision Sealed Wheel and Swivel (rotational deck if applicable) Bearings	✓
"No-Bend" Heavy-Duty Auto-Hitch and Self Stowing, Reinforced Towbar	✓
Heavy Duty Floor Lock w/Auto-Release (towbar activated)	✓
Leak-proof deck Containment Pan	✓
Cart Tare Weight	267 lbs.
Deck Load Capacity	1000 lbs.
Rated Load Capacity (to meet ergo guidelines w/standard wheels)	1000 lbs.